

TOSHIBA MOS MEMORY PRODUCTS

256K BIT (32K WORD × 8 BIT) MASK ROM
N-CHANNEL SILICON GATE

TMM23256P

020668

DESCRIPTION

The TMM23256P is a 262,144 bit read only memory organized as 32,768 words by 8 bits with a low bit cost, thus being most suitable for use in character generator.

Consisting of static memory cells and clocked peripheral circuitry, the TMM23256P provides a high speed and low power dissipation (access time 150ns, operating current 40mA).

The TMM23256P also features an automatic stand-by power mode. When deselected by Chip Enable (\overline{CE}), the operating current is reduced from 40mA to

FEATURES

- Single 5V Power Supply
- Fast Access Time : 150ns (Max.)
- Low Power Dissipation
 - Average Current : 40mA (Max.)
 - Standby Current : 10mA (Max.)
- Inputs protected : All Inputs have Protection Against Static Charge

10mA. Output Enable (\overline{OE}) is effective in preventing data conflict on a common bus line.

The TMM23256P uses the address latch system that the falling edge of \overline{CE} latches all inputs except for \overline{OE} , thus can be easily connected to a system where address and data buses are commonly used.

The TMM23256P is fabricated with ion implanted N-channel silicon gate technology. This technology allows a production on high performance.

The TMM23256P is moulded in a 28 pin standard plastic package, 0.6 inch in width.

- Edge Enabled Operation : \overline{CE}
- Output Buffer Control : \overline{OE}
- Input and Output : TTL Compatible
- Three State Outputs : Wired OR Capability
- 28 pin Standard Plastic DIP

PIN CONNECTION

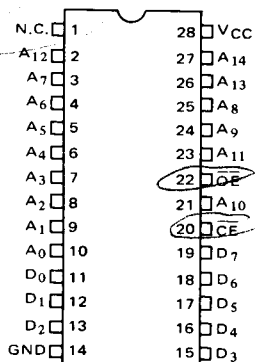

PIN NAMES

$A_0 \sim A_{14}$	Address Inputs
$D_0 \sim D_7$	Data Outputs
\overline{OE}	Output Enable Input
\overline{CE}	Chip Enable Input
N.C.	No Connection
V_{CC}	Power Supply Terminal
GND	Ground

BLOCK DIAGRAM

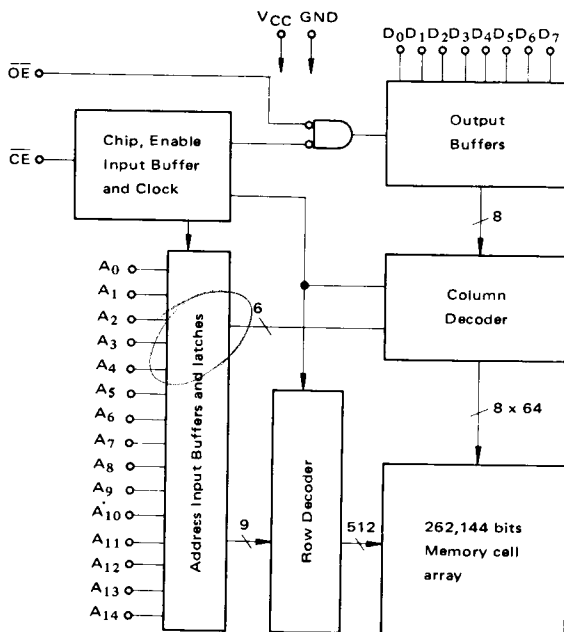

TMM23256P

MAXIMUM RATINGS

SYMBOL	ITEM	RATING	UNIT
V_{CC}	Power Supply Voltage	-0.5 ~ 7.0	V
V_{IN}, V_{OUT}	Input and Output Voltage	-0.5 ~ 7.0	V
T_{OPR}	Operating Temperature	0 ~ 70	°C
T_{STRG}	Storage Temperature	-55 ~ 150	°C
T_{SOLDER}	Soldering Temperature · Time	260 · 10	°C · sec
P_D	Power Dissipation ($T_a = 70^{\circ}\text{C}$)	1.0	W

D.C. OPERATING CONDITIONS ($T_a = 0 \sim 70^{\circ}\text{C}$)

SYMBOL	PARAMETER	CONDITIONS	MIN.	TYP.	MAX.	UNIT
V_{IH}	Input High Voltage	-	2.2	-	$V_{CC} + 1$	V
V_{IL}	Input Low Voltage	-	-0.5	-	0.8	V
V_{CC}	Power Supply Voltage	-	4.5	5.0	5.5	V

D.C. and OPERATING CHARACTERISTICS ($T_a = 0 \sim 70^{\circ}\text{C}$)

SYMBOL	PARAMETER	CONDITIONS	MIN.	TYP.	MAX.	UNIT	
I_{IH}	Input High Current	$V_{IN} = 5.5\text{V}$	-	0.05	10	μA	
I_{IL}	Input Low Current	$V_{IN} = \text{GND}$	-	-0.05	-10	μA	
V_{OH}	Output High Voltage	$I_{OH} = -400\mu\text{A}$	2.4	3.3	-	V	
V_{OL}	Output Low Voltage	$I_{OL} = 3.2\text{mA}$	-	0.3	0.4	V	
I_{LOH}	Output Leakage Current	$V_{OUT} = 5.5\text{V}$ $V_{OUT} = 0.4\text{V}$	$\overline{\text{CE}} = 2.2\text{V}$ or $\overline{\text{OE}} = 2.2\text{V}$	-	0.05	10	μA
I_{LOL}				-	-0.1	-20	μA
I_{CC1}	Standby Current	$\overline{\text{CE}} = 2.2\text{V}$	-	-	10	mA	
I_{CC2}	Average Current	$t_{CYC} = 230\text{ns}$, $I_{OUT} = 0\text{mA}$	-	-	40	mA	

- Typical values are at $T_a = 25^{\circ}\text{C}$ and $V_{CC} = 5\text{V}$.

CAPACITANCE ($T_a = 25^{\circ}\text{C}$, $f = 1\text{MHz}$)

SYMBOL	PARAMETER	CONDITIONS	MIN.	TYP.	MAX.	UNIT
C_{IN}	Input Capacitance	$V_{IN} = \text{A.C. GND}$	-	5	10	pF
C_{OUT}	Output Capacitance	$V_{OUT} = \text{A.C. GND}$	-	8	15	pF

Note : This parameter is periodically sampled and is not 100% tested.

A.C. CHARACTERISTICS (Ta = 0 ~ 70°C, VCC = 5V ± 10%)

SYMBOL	PARAMETER	CONDITIONS	MIN.	TYP.	MAX.	UNIT
t _{CE}	CE pulse width	—	150	—	—	ns
t _{AS}	Address Setup Time	—	0	—	—	ns
t _{AH}	Address Hold Time	—	30	—	—	ns
t _{ACC}	Access Time	—	—	—	150	ns
t _{OO}	Output Delay Time form OE	—	—	—	70	ns
t _{OD}	Output Turn off Delay	—	—	—	70	ns
t _{CC}	CE off Time	—	70	—	—	ns
t _{CYC}	Cycle Time	t _{AS} = 0ns, t _r , t _f = 5ns	230	—	—	ns

- Typical values are at Ta = 25°C and VCC = 5V.

A.C. TEST CONDITIONS

- Output Load : 1TTL Gate + 100pF
- Input Rise and Fall Times (10% ~ 90%) : 5ns
- Input Pulse Levels : 0.8 ~ 2.4V
- Timing Measurement Reference Levels : Input ; 1V and 2.2V
Output ; 0.8V and 2.0V

TIMING WAVEFORMS

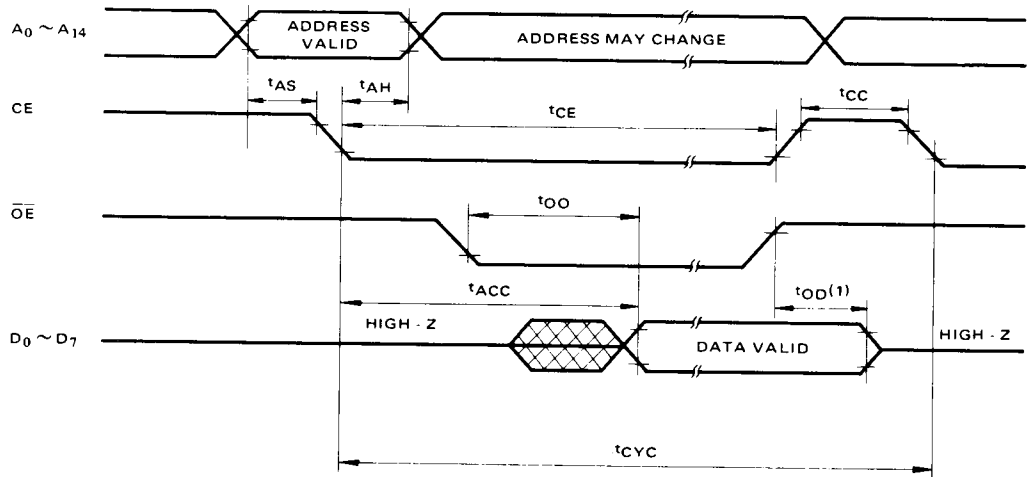

Note (1) t_{OD} is specified from OE or CE, whichever occurs first.

TMM23256P

OPERATION INFORMATION

The TMM23256P has two control functions.

The chip enable (\overline{CE}) controls the operation power and should be used for device selection. The falling edge of the \overline{CE} will activate the device and latch the addresses. The output enable (\overline{OE}) control the out-

put buffers, independent of device selection. Assuming that $\overline{OE} = V_{IL}$, the output data is valid at the outputs after t_{ACC} (150ns) from the falling edge of the \overline{CE} .

The operation modes of the TMM23256P are listed in the following table.

MODE	\overline{CE}	ADDRESS	\overline{OE}	OUTPUT	POWER
Standby	H	*	*	High Impedance	Standby
Latch		Valid	*	High Impedance	—
Read	L	**	L	Data Out	Active
Output Deselect	L	*	H	High Impedance	Active

Note * : Don't care

** : Address may change after t_{AH} .

APPLICATION INFORMATION

1. POWER SUPPLY DECOUPLING

The operating current I_{CC} waveforms for TMM 23256P are shown in Fig. 1, 2.

The TMM23256P is a clocked device, so the transient current peaks are produced on the \overline{CE} transition and \overline{CE} active level.

The I_{CC} current transients require adequate decoupling of V_{CC} power supply.

2. POWER ON

The TMM23256P requires initialization prior to normal operation. Two initialization methods are as follows:

- (1) A minimum $100\mu\text{s}$ time delay is required after the application of V_{CC} (+5V) before proper device operation is achieved. And during this period, \overline{CE} must be at V_{IH} level.
- (2) A minimum $100\mu\text{s}$ time delay is required after the application of V_{CC} (5V), and then a minimum of one initialization cycle must be performed before proper device operation is achieved.

Initialization cycle : An initialization cycle is one Chip Enable clock cycle from the first down edge of the \overline{CE} till the next down edge.

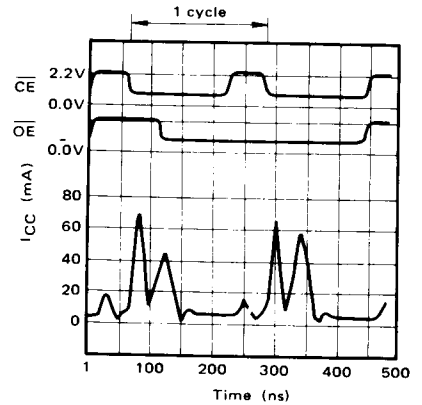

Fig. 1 I_{CC} vs. Time (1)

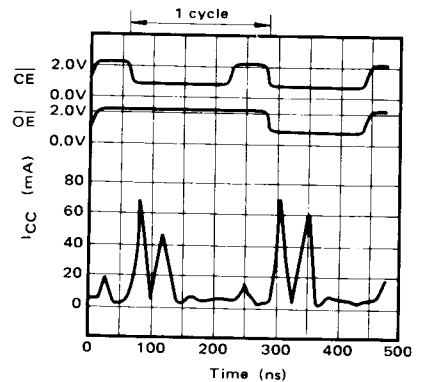
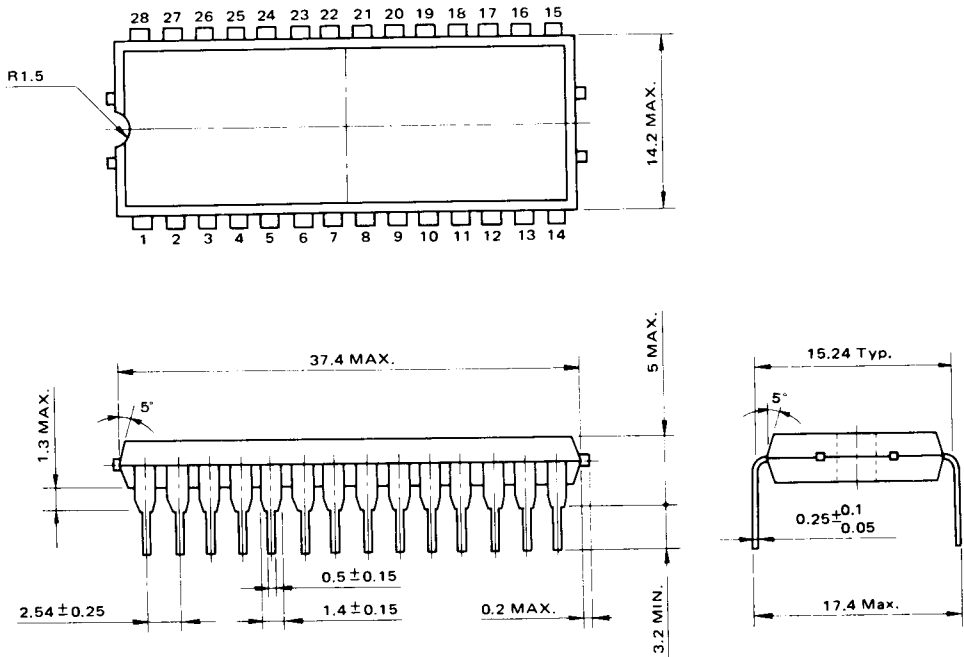

Fig. 2 I_{CC} vs. Time (2)

TMM23256P

OUTLINE DRAWINGS

Unit : mm



Note : Each lead pitch is 2.54mm. All leads are located within 0.25mm of their true longitudinal position with respect to No.1 and No.28 leads.

This datasheet has been downloaded from:

www.DatasheetCatalog.com

Datasheets for electronic components.